

REPAIR PARTS MANUAL
MODEL NO. WZ125107B
LAWN TRACTOR

WIZARD

HOW TO USE THIS MANUAL

This manual is designed to provide the customer with a means to identify the parts on his/her tractor when ordering repair parts. The illustrations may or may not represent the actual assemblies; therefore, it is not recommended to use this manual as a guide to assemble or disassemble the tractor. Some hardware and parts are drawn larger in order to more readily identify them.

Each tractor has its own model number.

The model number for your tractor can be found on the fender under the seat.

When ordering parts, always give the following information:

- Product - "Lawn Tractor"
- Model Number - "WZ125107B"
- Part Number
- Part Description

TABLE OF CONTENTS

SCHEMATIC	3
ELECTRICAL	4-5
CHASSIS	6-7
DRIVE	8-9
STEERING	10-11
ENGINE	12-13
SEAT	14
DECALS	15
MOWER DECK	16-17
MOWER LIFT LEVER	18-19

TRACTOR - MODEL NO. WZ125107B, PRODUCT NO. 964 77 35-02
SCHEMATIC

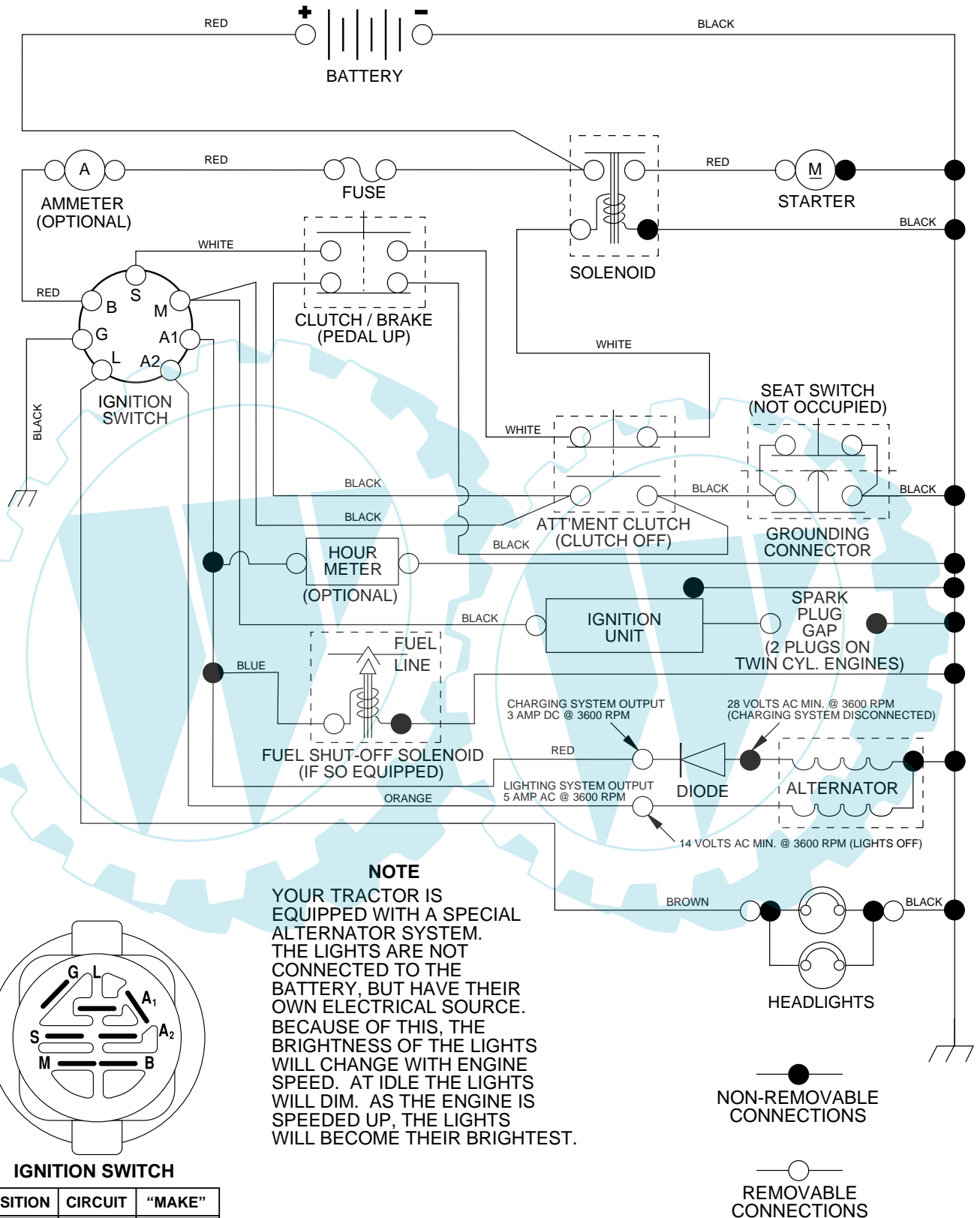

REPAIR PARTS

TRACTOR - MODEL NO. WZ125107B, PRODUCT NO. 964 77 35-02

ELECTRICAL

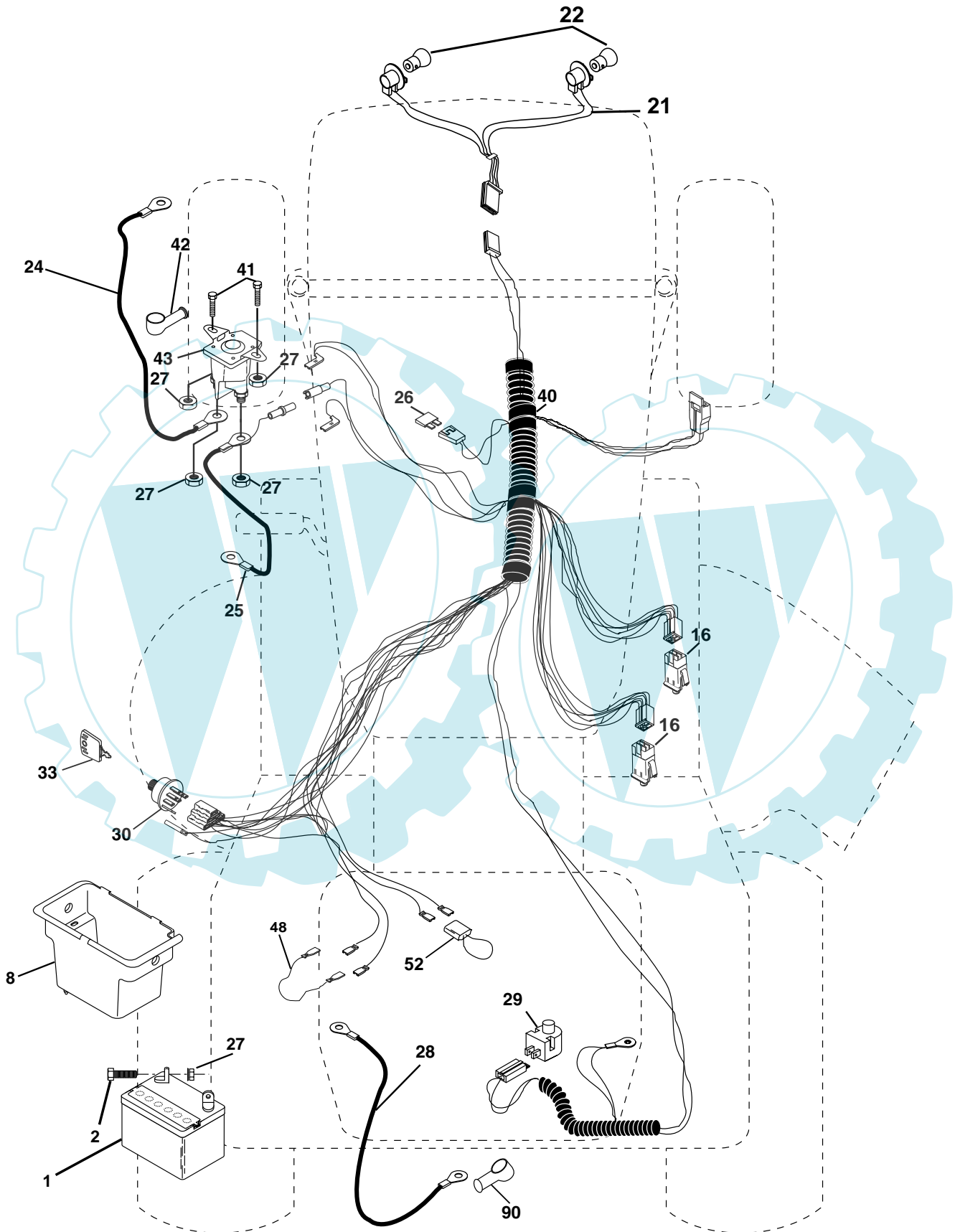

REPAIR PARTS

TRACTOR - MODEL NO. WZ125107B, PRODUCT NO. 964 77 35-02
ELECTRICAL

KEY NO.	PART NO.	DESCRIPTION
2	874 76 04-12	Bolt Hex Hd 1/4-20 unc x 3/4
8	532 17 66-89	Battery Box
16	532 17 61-38	Switch Interlock Push-In
21	532 18 37-59	Harness Asm Light W/4152j
22	532 00 41-52	Bulb Light #1156
24	532 12 47-80	Cable Battery 6 Ga. 11" red
25	532 14 61-47	Cable Battery 6 Ga. 44" red w/16 wire
26	532 17 51-58	Fuse 20 AMP
27	873 51 04-00	Nut Keps Hex 1/4-20 unc
28	532 12 47-73	Cable Ground 6 Ga. 12" black
29	532 12 13-05	Switch Plunger Nc Gray
30	532 17 55-66	Switch Ign
33	532 14 04-01	Key Ign Molded Generic
40	532 17 97-20	Harness Ign.
41	871 11 04-08	Bolt Blk Fin Hex 1/4 - 20 x 1/2
42	532 13 15-63	Cover Terminal Red
43	532 17 88-61	Solenoid
48	532 14 08-44	Adapter Ammeter Rectangular
52	532 14 19-40	Protection Wire Loop
90	532 18 04-49	Cover Terminal Battery

NOTE: All component dimensions given in U.S. inches.
1 inch = 25.4 mm.

REPAIR PARTS

TRACTOR - MODEL NO. WZ125107B, PRODUCT NO. 964 77 35-02

CHASSIS

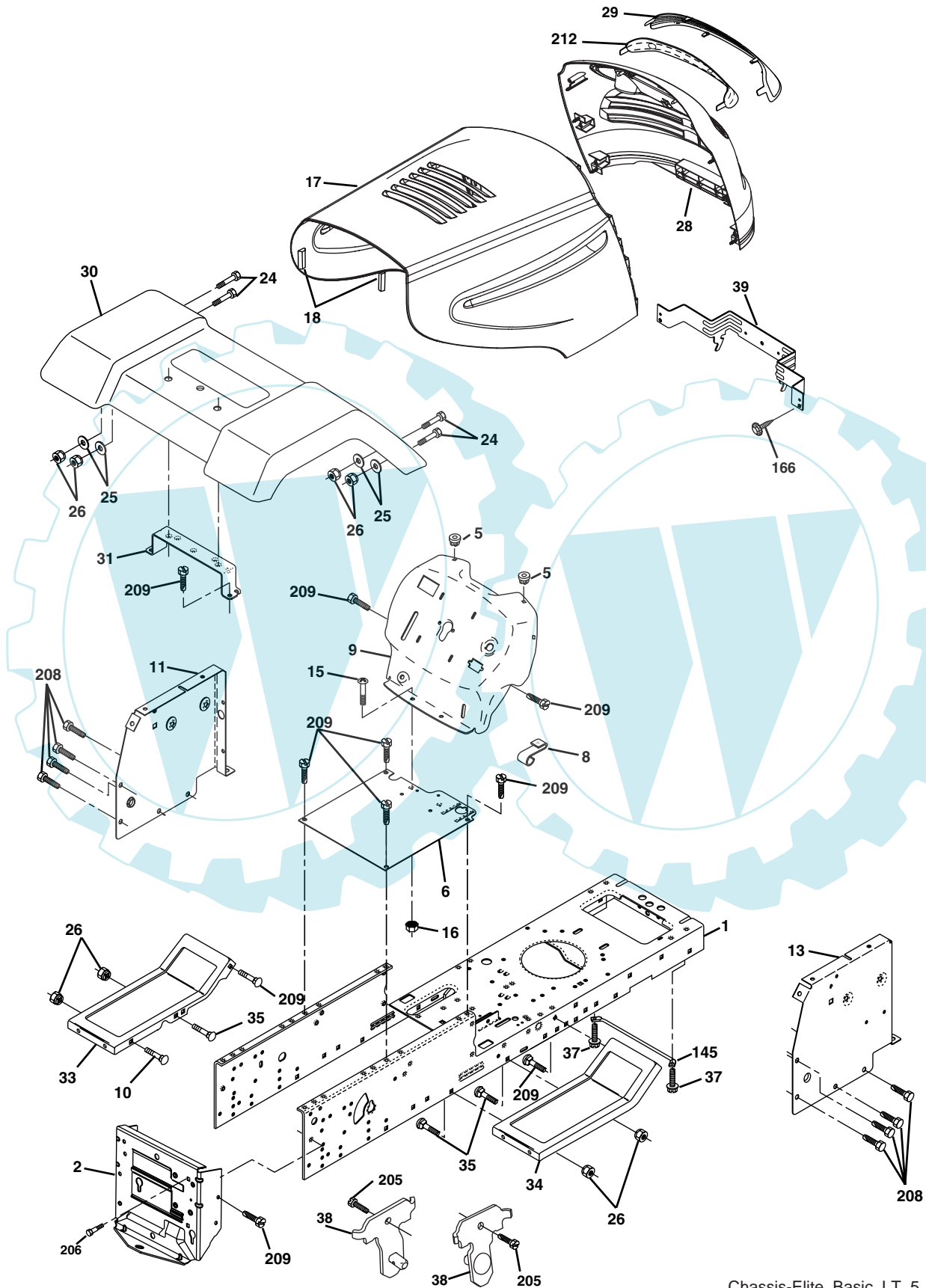

Chassis-Elite_Basic_LT_5

REPAIR PARTS

TRACTOR - MODEL NO. WZ125107B, PRODUCT NO. 964 77 35-02
CHASSIS

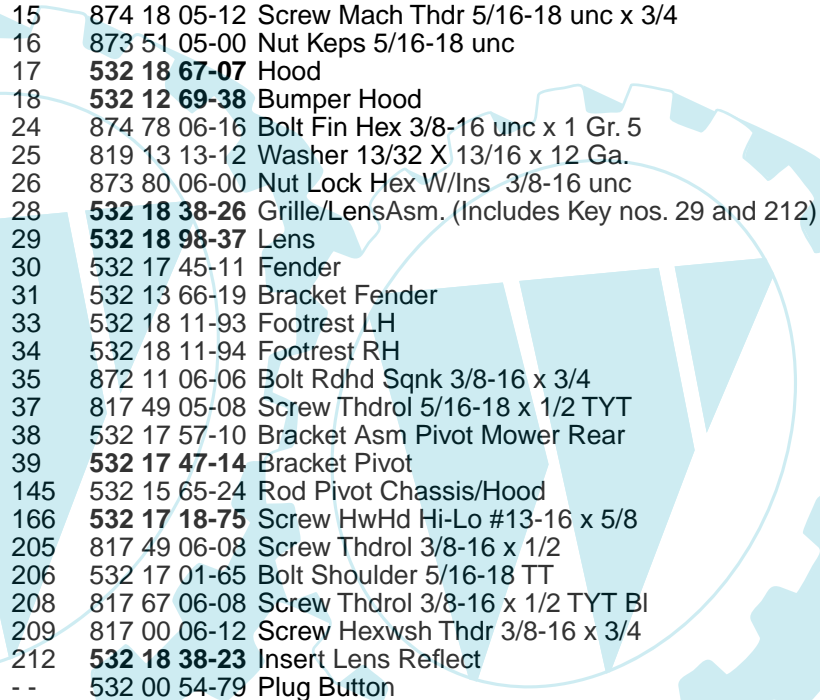

KEY NO.	PART NO.	DESCRIPTION
1	532 17 46-20	Chassis Stamping
2	532 17 65-54	Drawbar
5	532 15 52-72	Bumper Hood/Dash
6	532 18 44-19	Saddle
8	532 15 51-38	Clip Retainer
9	532 18 54-80	Dash
10	872 14 06-08	Bolt Carriage 3/8-16 x 1
11	532 17 49-96	Panel Dash Lh
13	532 18 69-52	Panel Dash Rh
15	874 18 05-12	Screw Mach Thdr 5/16-18 unc x 3/4
16	873 51 05-00	Nut Keps 5/16-18 unc
17	532 18 67-07	Hood
18	532 12 69-38	Bumper Hood
24	874 78 06-16	Bolt Fin Hex 3/8-16 unc x 1 Gr. 5
25	819 13 13-12	Washer 13/32 X 13/16 x 12 Ga.
26	873 80 06-00	Nut Lock Hex W/Ins 3/8-16 unc
28	532 18 38-26	Grille/LensAsm. (Includes Key nos. 29 and 212)
29	532 18 98-37	Lens
30	532 17 45-11	Fender
31	532 13 66-19	Bracket Fender
33	532 18 11-93	Footrest LH
34	532 18 11-94	Footrest RH
35	872 11 06-06	Bolt Rdhd Sqnk 3/8-16 x 3/4
37	817 49 05-08	Screw Thdrol 5/16-18 x 1/2 TYT
38	532 17 57-10	Bracket Asm Pivot Mower Rear
39	532 17 47-14	Bracket Pivot
145	532 15 65-24	Rod Pivot Chassis/Hood
166	532 17 18-75	Screw HwHd Hi-Lo #13-16 x 5/8
205	817 49 06-08	Screw Thdrol 3/8-16 x 1/2
206	532 17 01-65	Bolt Shoulder 5/16-18 TT
208	817 67 06-08	Screw Thdrol 3/8-16 x 1/2 TYT Bl
209	817 00 06-12	Screw Hexwsh Thdr 3/8-16 x 3/4
212	532 18 38-23	Insert Lens Reflect
--	532 00 54-79	Plug Button

NOTE: All component dimensions given in U.S. inches
1 inch = 25.4 mm

REPAIR PARTS

TRACTOR - MODEL NO. WZ125107B, PRODUCT NO. 964 77 35-02

DRIVE

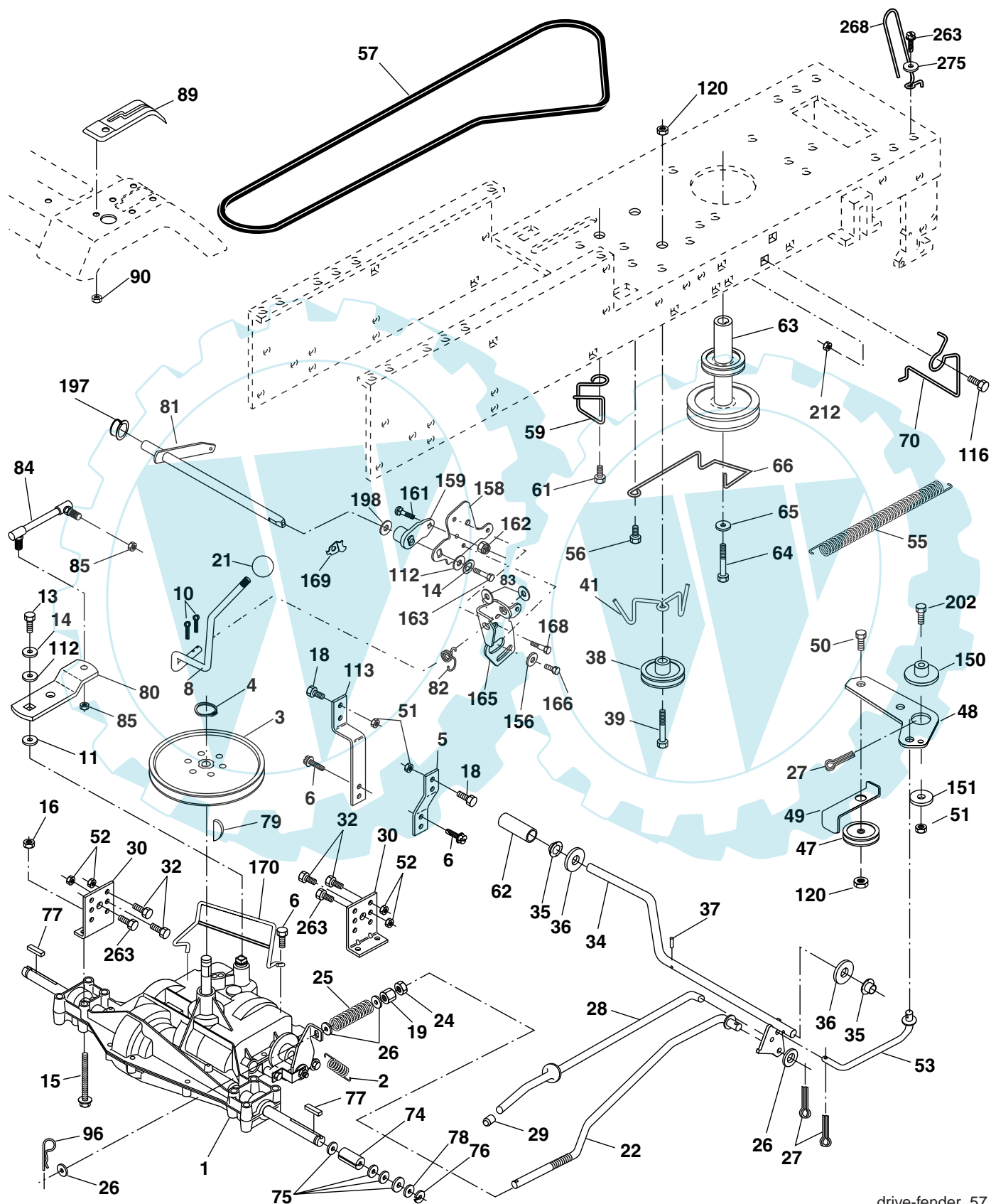

drive-fender_57

REPAIR PARTS

TRACTOR - MODEL NO. WZ125107B, PRODUCT NO. 964 77 35-02

DRIVE

KEY NO.	PART NO.	DESCRIPTION	KEY NO.	PART NO.	DESCRIPTION
1	-----	Transaxle, Peerless 205-544C (Order Parts From Transaxle Manufacturer)	64	532 17 39-37	Bolt Hex 7/16-20 x 4 x Gr. 5
2	532 14 66-82	Spring Return Brake T/a Zinc	65	810 04 07-00	Washer Lock Hvy Hlcl Spr 7/16
3	532 12 36-66	Pulley Transaxle 18" tires	66	532 15 47-78	Keeper Belt Engine Foolproof
4	812 00 00-28	Ring Retainer # 5100-62	70	532 18 02-18	Guide Belt Mower Drive RH
5	532 12 15-20	Strap Torque 30 Degrees	74	532 13 70-57	Spacer Axle
6	817 00 05-12	Screw Thdrol 5/16-18 x 3/4 TYT	75	532 12 17-49	Washer 25/32 x 1 1/4 x 16 Ga.
8	532 16 56-19	Rod Shift Fender Adjust	76	812 00 00-01	E-ring #5133-75
10	876 02 04-16	Pin Cotter 1/8 x 1 Cad	77	532 12 35-83	Key Square 2 0 x 1845/ 1865
11	532 10 57-01	Washer Plate Shf 388 Sq Hole	78	532 12 17-48	Washer 25/32 x 1-5/8 x 16 Ga.
13	874 55 04-12	Bolt 1/4-28 Unf Gr. 8 W/Patch	79	532 12 50-96	Key Woodruff #9 3/16 x 3/4
14	810 04 04-00	Washer Lock Hvy Helical 1/4	80	532 13 14-86	Arm Shift
15	874 49 05-44	Bolt Hex Flg Hd 5/16-18 Gr. 5	81	532 16 55-94	Shaft Asm Cross Tapered DA/PR 18"
16	873 80 05-00	Nut Lock Hx W/Ins 5/16-18 Unc Pl	82	532 12 37-82	Spring Torsion T/a
18	874 78 06-16	Bolt, Fin Hex 3/8-16 unc x 1 Gr. 5	83	819 17 12-16	Washer 17/32 x 3/4 x 16 Ga.
19	873 80 06-00	Nut Lock 3/8-16 unc	84	532 16 62-28	Transaxle Link
21	532 10 69-33	Knob	85	532 15 03-60	Nut Lock Center 1/4 - 28 FNTHD
22	532 13 08-04	Rod Brake Blk Zinc 26 840	89	532 17 37-74	Console Shift
24	873 35 06-00	Nut Hex Jam 3/8-16 Unc	90	532 12 43-46	Nut Self-thd Wsh-hd 1/4 Zinc
25	532 10 68-88	Spring Rod Brake 2 00 Zinc	96	532 12 47-88	Retainer Spring 1"
26	819 13 13-16	Washer 13/32 x 13/16 x 16 Ga.	112	819 09 12-10	Washer 9/32 x 3/4 x 10 Ga.
27	876 02 04-12	Pin Cotter 1/8 x 3/4 Cad	113	532 12 72-85	Strap Torque LT
28	532 17 57-65	Rod Brake Parking LT/YT	116	872 14 06-08	Bolt Rdhd Sq Neck 3/8-16 x 1
29	532 07 16-73	Cap Brake Parking Black	120	873 90 06-00	Nut Lock Flg. 3/8-16
30	532 17 49-73	Bracket Mtg Transaxle	150	532 17 54-56	Spacer Retainer
32	874 76 05-12	Bolt Hex Hd 5/16-18 unc x 3/4	151	819 13 32-10	Washer 13/32 x 2 x 10 Ga.
34	532 17 55-78	Shaft Asm Pedal Foot	156	532 16 60-02	Washer Srrted 5/16 ID x 1.125
35	532 12 01-83	Bearing Nylon Blk 629 Id	158	532 16 55-89	Bracket Shift Mount
36	819 21 16-16	Washer 21/32 x 1 x 16 Ga.	159	532 18 39-00	Hub Shift
37	532 12 49-63	Pin Roll 3/16 x 1"	161	872 14 04-06	Bolt Rdhd Sqnc 1/4-20 x 3/4 Gr. 5
38	532 17 91-14	Pulley Composite	162	873 68 04-00	Nut Crownlock 1/4-20 unc
39	872 11 06-22	Bolt Fin Hex 3/8-16 unc x 2-3/4 Gr. 5	163	874 78 04-16	Bolt Hex Fin 1/4-20 unc x 1 Gr. 5
41	532 17 55-56	Keeper Belt Idler Flat	165	532 16 56-23	Bracket Pivot Lever
47	532 12 77-83	Pulley Idler V Groove Plastic	166	817 49 05-10	Screw 5/16-18 x 5/8
48	532 15 44-07	Bellcrank Clutch Grnd Drv Stl	168	532 16 54-92	Bolt Shoulder 5/16-18 x .561
49	532 12 32-05	Retainer Belt Style Spring	169	532 16 55-81	Plate Fastening STLT/CRD
50	872 11 06-12	Bolt Hex Hd 3/8-16 unc x 1-1/2 Gr.5	170	532 18 74-14	Keeper Belt T/A
51	873 68 06-00	Nut Crownlock 3/8-16 unc	171	817 49 06-08	Screw Thdrol 3/8-16 x 1/2
52	873 68 05-00	Nut Crownlock 5/16-18 unc	197	532 16 96-13	Nyliner Snap-In 5/8" ID
53	532 10 57-10	Link Clutch	202	872 11 06-14	Bolt Carr Sh 3/8-16 x 1-3/4 Gr. 5
55	532 10 57-09	Spring Return Clutch 6 75	207	532 16 98-45	Washer Nylon
56	817 06 06-20	Screw 3/8-16 x 1-1/4	212	532 14 52-12	Nut Hex Flg Lock
57	532 13 08-01	V-Belt Ground Drive 95 25	263	817 00 06-12	Screw 3/8-16 x 3/4
59	532 16 96-91	Keeper Belt Span Ctr	268	532 18 24-02	Guard, Muffler RH
61	817 12 06-14	Screw 3/8-16 x .875	275	819 13 16-14	Washer 13/32 x 1 x 14 Ga.
62	532 12 48-72	Cover Pedal			
63	532 18 02-19	Engine Pulley LT/YT			

NOTE: All component dimensions given in U.S. inches
1 inch = 25.4 mm

REPAIR PARTS

TRACTOR - MODEL NO. WZ125107B, PRODUCT NO. 964 77 35-02
STEERING ASSEMBLY

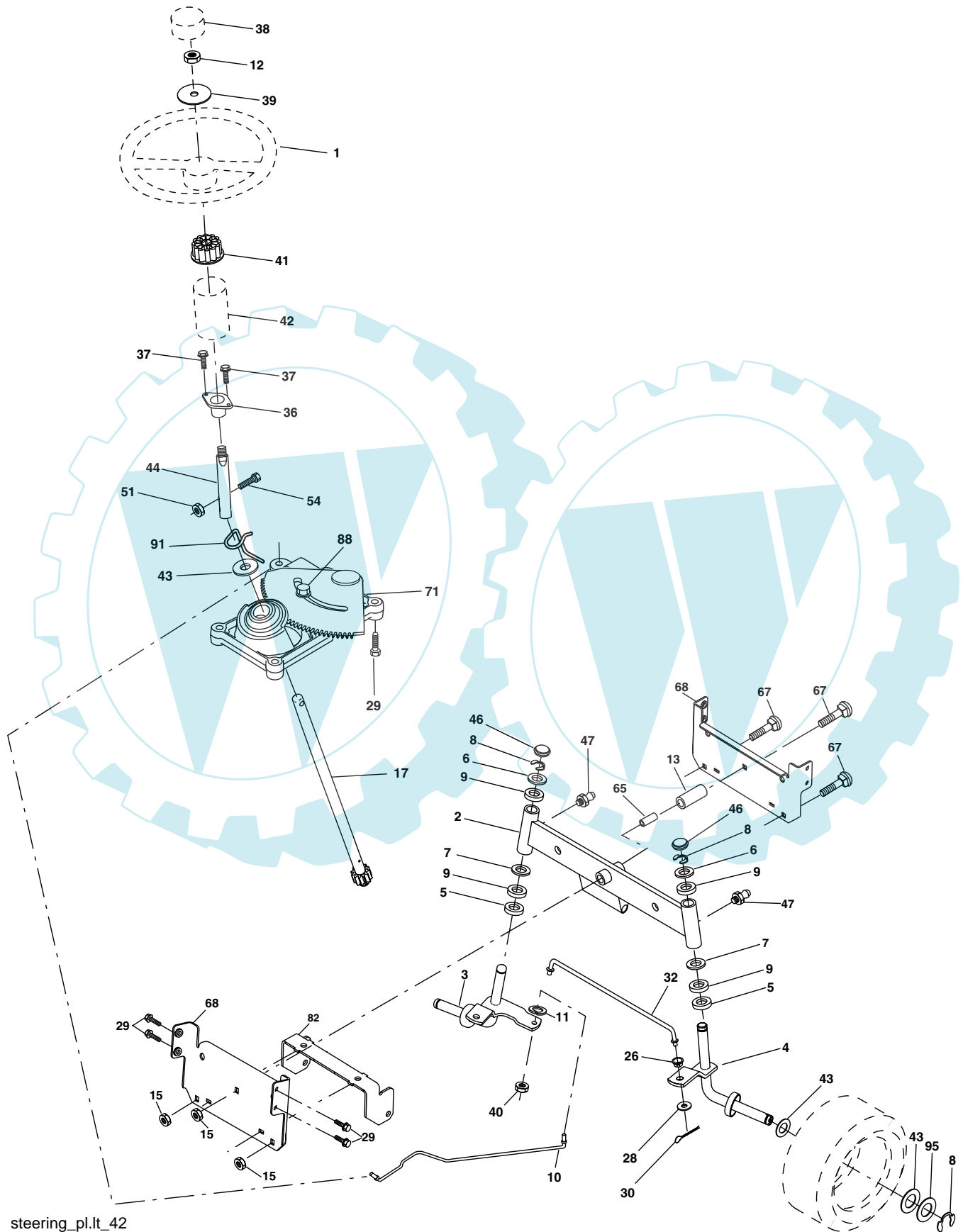

steering_pl.lt_42

REPAIR PARTS

TRACTOR - MODEL NO. WZ125107B, PRODUCT NO. 964 77 35-02 STEERING ASSEMBLY

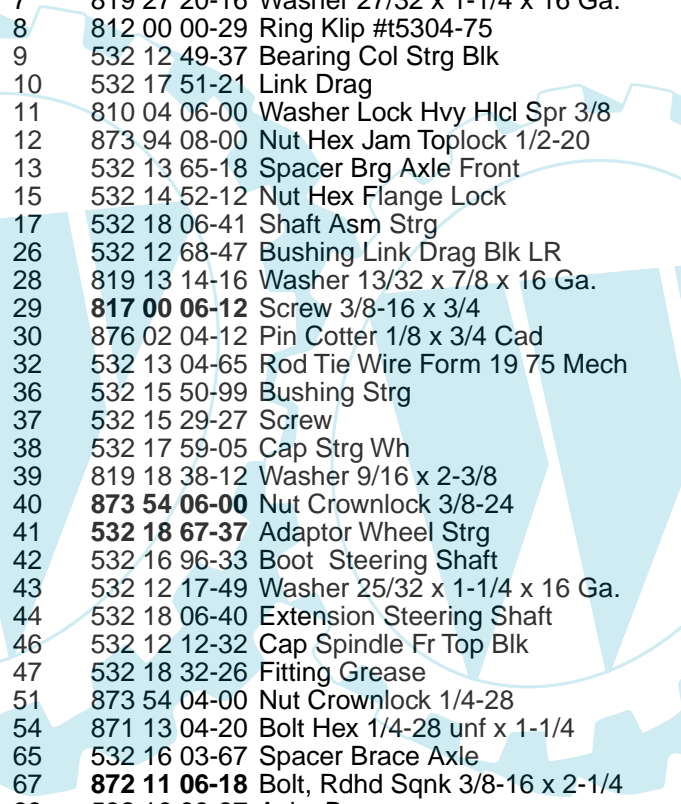

KEY NO.	PART NO.	DESCRIPTION
1	532 17 59-04	Wheel Steering
2	532 17 51-31	Axle Asm
3	532 16 98-40	Spindle Asm LH
4	532 16 98-39	Spindle Asm RH
5	532 12 49-31	Bearing Race Thrust Harden
6	532 12 17-48	Washer 25/32 x 1-5/8 x 16 Ga.
7	819 27 20-16	Washer 27/32 x 1-1/4 x 16 Ga.
8	812 00 00-29	Ring Klip #15304-75
9	532 12 49-37	Bearing Col Strg Blk
10	532 17 51-21	Link Drag
11	810 04 06-00	Washer Lock Hvy Hlcl Spr 3/8
12	873 94 08-00	Nut Hex Jam Toplock 1/2-20
13	532 13 65-18	Spacer Brg Axle Front
15	532 14 52-12	Nut Hex Flange Lock
17	532 18 06-41	Shaft Asm Strg
26	532 12 68-47	Bushing Link Drag Blk LR
28	819 13 14-16	Washer 13/32 x 7/8 x 16 Ga.
29	817 00 06-12	Screw 3/8-16 x 3/4
30	876 02 04-12	Pin Cotter 1/8 x 3/4 Cad
32	532 13 04-65	Rod Tie Wire Form 19 75 Mech
36	532 15 50-99	Bushing Strg
37	532 15 29-27	Screw
38	532 17 59-05	Cap Strg Wh
39	819 18 38-12	Washer 9/16 x 2-3/8
40	873 54 06-00	Nut Crownlock 3/8-24
41	532 18 67-37	Adaptor Wheel Strg
42	532 16 96-33	Boot Steering Shaft
43	532 12 17-49	Washer 25/32 x 1-1/4 x 16 Ga.
44	532 18 06-40	Extension Steering Shaft
46	532 12 12-32	Cap Spindle Fr Top Blk
47	532 18 32-26	Fitting Grease
51	873 54 04-00	Nut Crownlock 1/4-28
54	871 13 04-20	Bolt Hex 1/4-28 unf x 1-1/4
65	532 16 03-67	Spacer Brace Axle
67	872 11 06-18	Bolt, Rdhd Sqnk 3/8-16 x 2-1/4
68	532 16 98-27	Axle, Brace
71	532 17 51-46	Steering Asm.
82	532 16 98-35	Bracket Susp Chassis Front
88	532 17 51-18	Bolt Shoulder 7/16-20
91	532 17 55-53	Clip Steering
95	532 18 89-67	Washer Harden .793 x 1.637 x .060

NOTE: All component dimensions given in U.S. inches.
1 inch = 25.4 mm.

REPAIR PARTS

TRACTOR - MODEL NO. WZ125107B, PRODUCT NO. 964 77 35-02

ENGINE

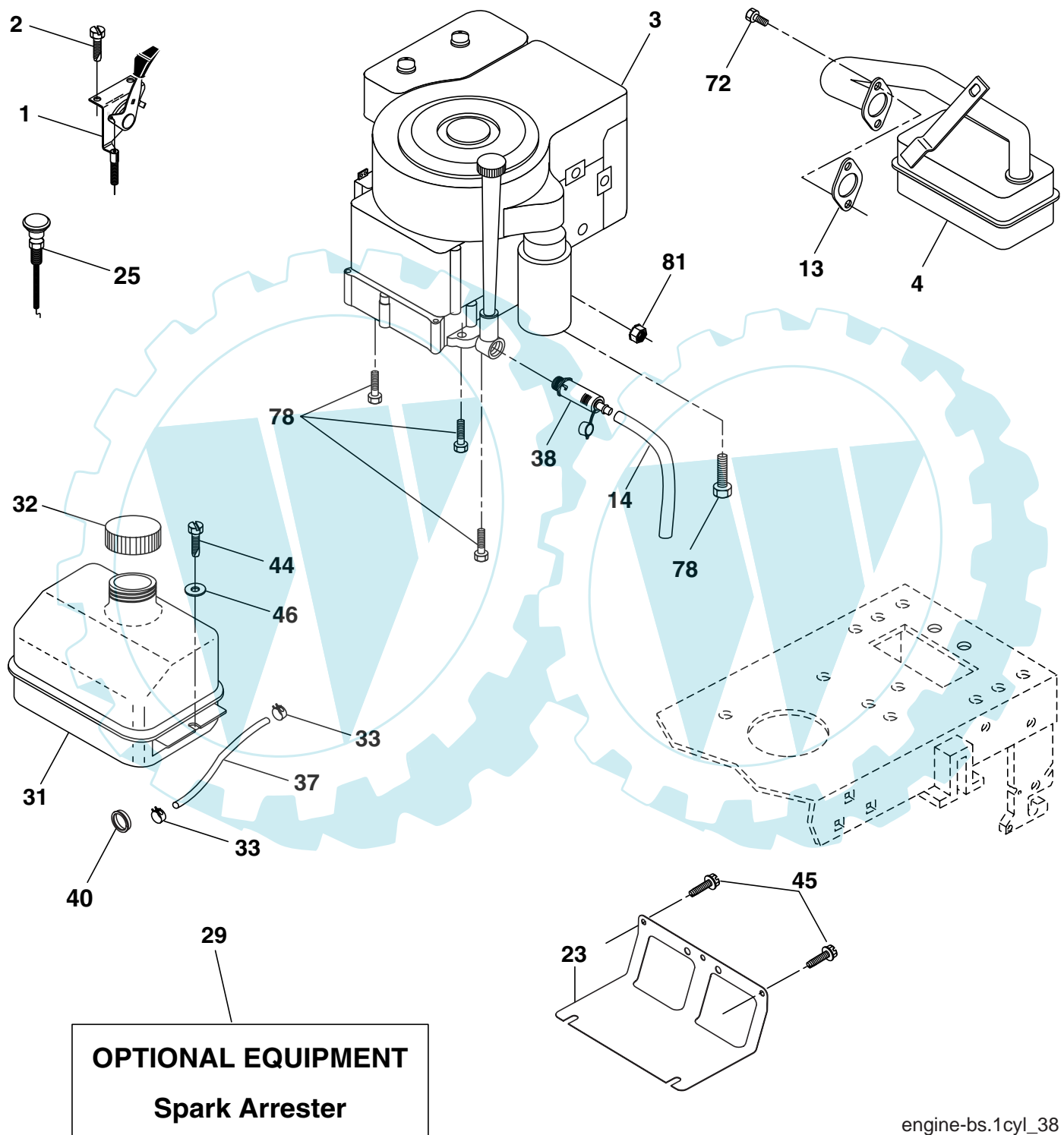

engine-bs.1cyl_38

REPAIR PARTS

TRACTOR - MODEL NO. WZ125107B, PRODUCT NO. 964 77 35-02
ENGINE

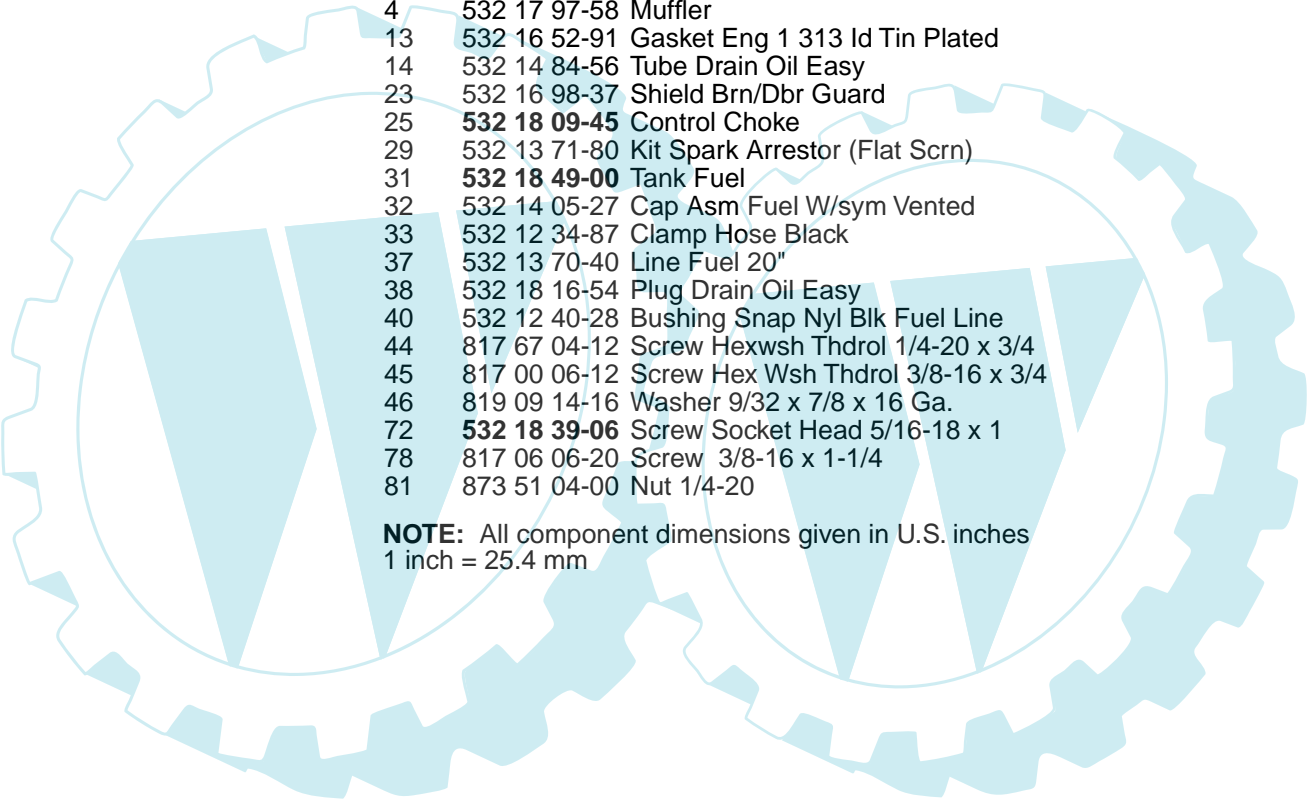

KEY NO.	PART NO.	DESCRIPTION
1	532 17 05-51	Control Th/ch Flag
2	817 72 04-08	Screw Hex Thd Cut 1/4-20 x 1/2
3	-----	Engine B&S Model No. 21A807 (Order Parts From Engine Manufacturer)
4	532 17 97-58	Muffler
13	532 16 52-91	Gasket Eng 1 313 Id Tin Plated
14	532 14 84-56	Tube Drain Oil Easy
23	532 16 98-37	Shield Brn/Dbr Guard
25	532 18 09-45	Control Choke
29	532 13 71-80	Kit Spark Arrestor (Flat Scrn)
31	532 18 49-00	Tank Fuel
32	532 14 05-27	Cap Asm Fuel W/sym Vented
33	532 12 34-87	Clamp Hose Black
37	532 13 70-40	Line Fuel 20"
38	532 18 16-54	Plug Drain Oil Easy
40	532 12 40-28	Bushing Snap Nyl Blk Fuel Line
44	817 67 04-12	Screw Hexwsh Thdrol 1/4-20 x 3/4
45	817 00 06-12	Screw Hex Wsh Thdrol 3/8-16 x 3/4
46	819 09 14-16	Washer 9/32 x 7/8 x 16 Ga.
72	532 18 39-06	Screw Socket Head 5/16-18 x 1
78	817 06 06-20	Screw 3/8-16 x 1-1/4
81	873 51 04-00	Nut 1/4-20

NOTE: All component dimensions given in U.S. inches
1 inch = 25.4 mm

REPAIR PARTS

TRACTOR - MODEL NO. WZ125107B, PRODUCT NO. 964 77 35-02
SEAT ASSEMBLY

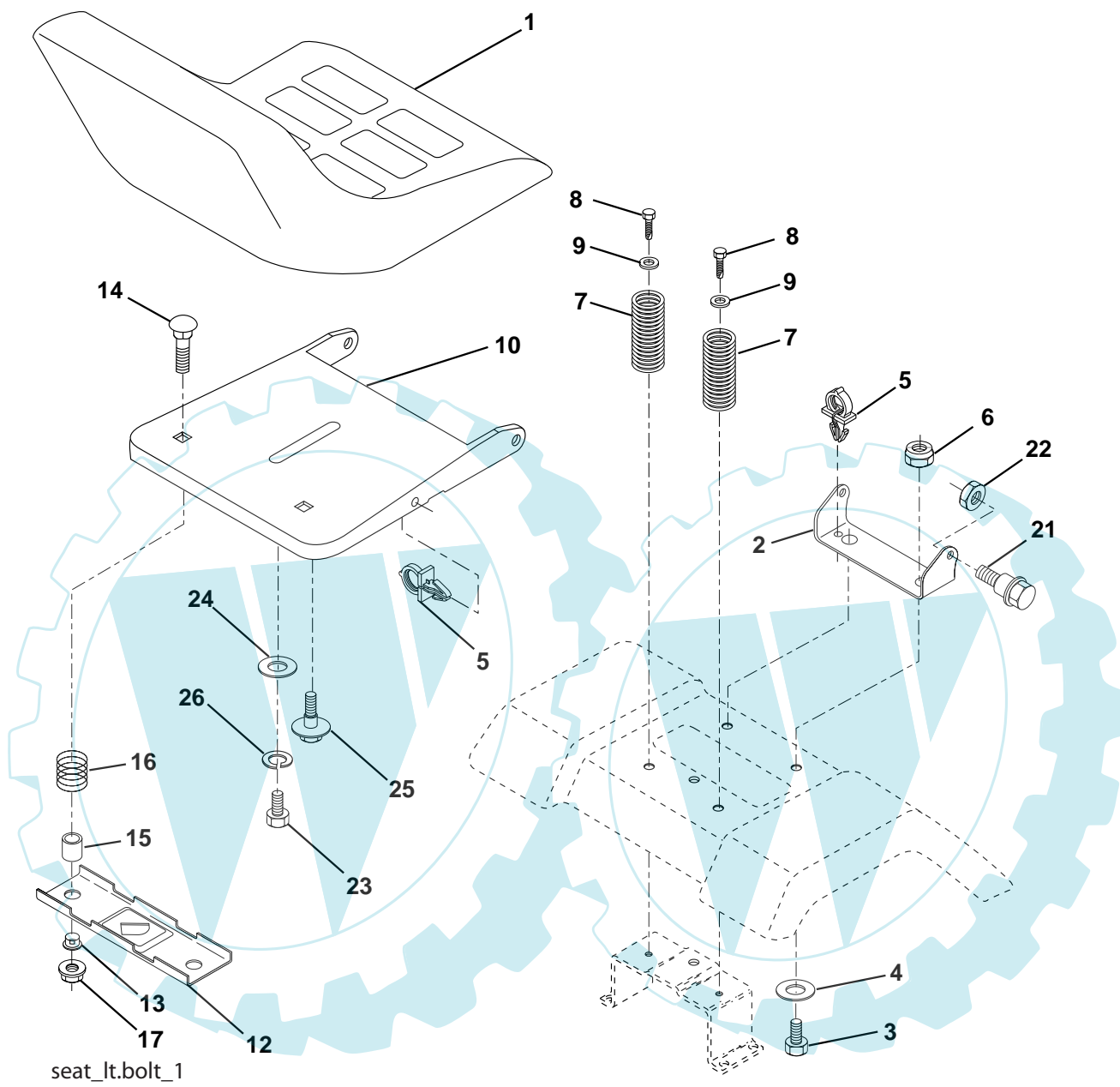

seat_lt.bolt_1

KEY NO.	PART NO.	DESCRIPTION
1	532 17 53-89	Seat
2	532 14 05-51	Bracket Pivot Seat 8 720
3	871 11 06-16	Bolt Fin Hex 3/8-16 unc x 1
4	819 13 16-10	Washer 13/32 x 1 x 10 Ga.
5	532 14 50-06	Clip Push-In
6	873 80 06-00	Nut Hex w/Ins. 3/8-16 Unc
7	532 12 41-81	Spring Seat Cprsn 2 250 Blk Zi
8	817 00 06-16	Screw 3/8-16 x 1-1/2
9	819 13 16-14	Washer 13/32 x 1 x 14 Ga.
10	532 18 24-93	Pan Seat
12	532 12 12-46	Bracket Mounting Switch
13	532 12 12-48	Bushing Snap Blk Nyl 50 Id

KEY NO.	PART NO.	DESCRIPTION
14	872 05 04-12	Bolt Rdhd Sqnk 1/4-20 x 1-1/2
15	532 13 43-00	Spacer Split 28x 96 Yel Zinc
16	532 12 12-50	Spring Cprsn 1 27 Blk Pnt
17	532 12 39-76	Nut Lock 1/4 Lge Flg Gr. 5 Zinc
21	532 17 18-52	Bolt Shoulder 5/16-18 Unc
22	873 80 05-00	Nut Hex Lock W/Ins 5/16-18
23	871 11 08-14	Bolt Hex
24	819 17 19-12	Washer 17/32 x 1-3/16 x 12 Ga.
25	532 12 70-18	Bolt Shoulder 5/16-18 x 62
26	810 04 08-00	Washer Lock Hvy HLCL SPR 1/2

NOTE: All component dimensions given in U.S. inches.
1 inch = 25.4 mm

REPAIR PARTS

TRACTOR - MODEL NO. WZ125107B, PRODUCT NO. 964 77 35-02

DECALS

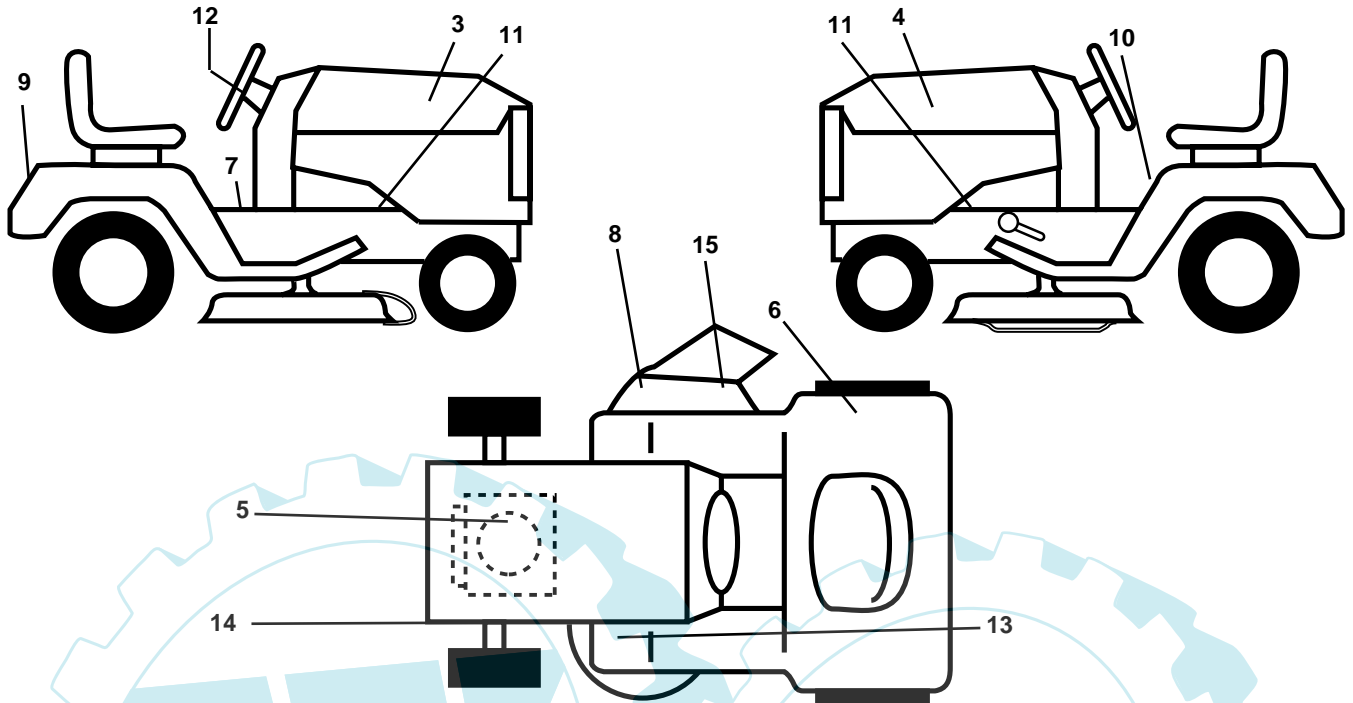

KEY NO.	PART NO.	DESCRIPTION
3	532 18 98-51	Decal Hood RH
4	532 18 98-52	Decal Hood LH
5	532 18 47-65	Decal HP Engine
6	532 18 04-32	Decal Fender 100 DB/CE
7	532 14 08-37	Decal Saddle Brake
8	532 17 91-28	Decal Deck "B" 42"
9	532 17 21-75	Decal Fender
10	532 14 54-98	Decal Read Owner's Manual Syms.
11	532 15 97-36	Decal Chassis Hot Muffler

KEY NO.	PART NO.	DESCRIPTION
12	532 16 71-08	Decal Wheel Steering
13	532 15 97-37	Decal Brake/Clutch Symbol LT
14	532 16 03-96	Decal V-Belt Schematic
15	532 18 21-66	Decal Mower Cutfinger Symbol
--	532 16 25-98	Decal Drawbar Load Limit
--	532 13 83-11	Decal Handle Lft Height Adjust
--	532 18 52-39	Manual Operator's (Euro)
--	532 18 52-40	Manual Operator's (Scand)
--	532 19 02-29	Manual Parts

WHEELS & TIRES

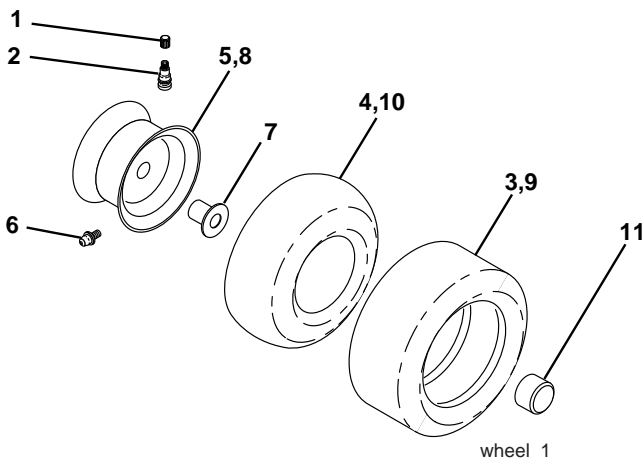

KEY NO.	PART NO.	DESCRIPTION
1	532 05 91-92	Cap Valve Tire
2	532 06 51-39	Stem Valve
3	532 10 62-22	Tire FTs 15 x 6 0 - 6 Service
4	532 05 99-04	Tube Front (Service Item Only)
5	532 18 33-37	Rim Asm 6" front Service
6	532 12 49-57	Fitting Grease (Front Wheel Only)
7	532 12 49-59	Bearing Flange (Front Wheel Only)
8	532 18 33-38	Rim Asm 8" rear Service
9	532 10 62-68	Tire RTs 18 x 8-9.5-8 C Service
10	532 12 49-26	Tube Rear (Service Item Only)
11	532 17 50-39	Cap Axle Blk 1 50 x 1 00
--	532 14 43-34	Sealant, Tire (10 oz. Tube)

NOTE: All component dimensions given in U.S. inches
1 inch = 25.4 mm

REPAIR PARTS

TRACTOR - MODEL NO. WZ125107B, PRODUCT NO. 964 77 35-02
MOWER DECK

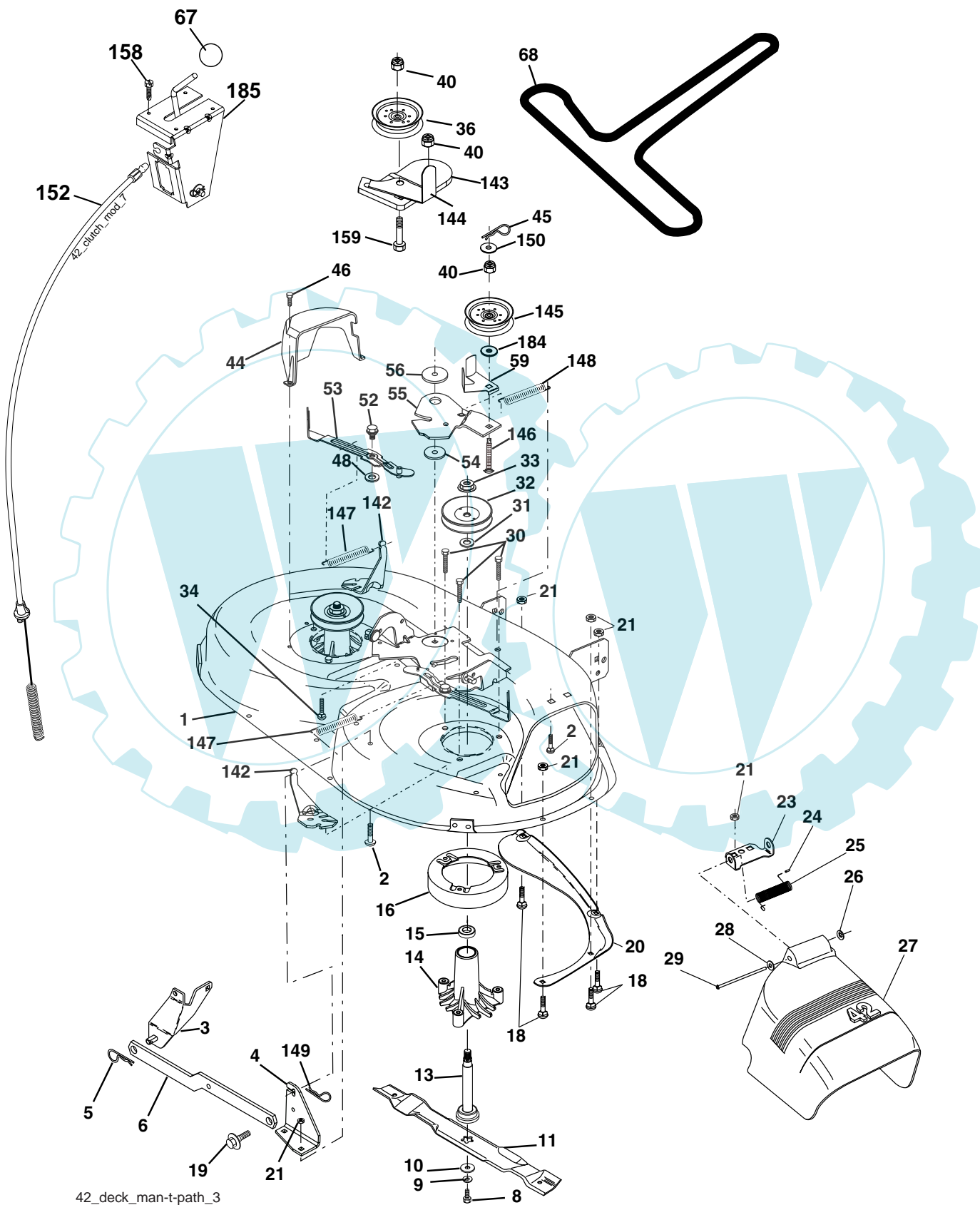

REPAIR PARTS

TRACTOR - MODEL NO. WZ125107B, PRODUCT NO. 964 77 35-02
MOWER DECK

KEY NO.	PART NO.	DESCRIPTION
1	532 16 58-92	Deck Asm MWR 42"weldment
2	872 14 05-06	Bolt Rdhd Sqnk 5/16-18 unc x 3/4
3	532 13 80-17	Bracket Asm Fr Sway Bar 38/42
4	532 16 54-60	Bracket Asm Deck 42"sway Bar
5	532 12 46-70	Retainer Spring
6	532 17 80-24	Bar Sway Deck
8	532 85 08-57	Bolt 3/8 - 24 x 1.25 Gr. 8
9	810 03 06-00	Washer Lock Hvy 3/8
10	532 14 02-96	Washer Hard Blade Mower Vented
11	532 13 84-98	Blade Mower 42"
13	532 13 76-45	Shaft Asm W/lower Bearing
14	532 12 87-74	Housing Mandrel Vented
15	532 11 04-85	Bearing Ball Mandrel
16	532 17 44-93	Stripper Mower Vented
18	872 14 05-05	Bolt Rdhd Sqnk 5/16-18 x 5/8
19	532 13 28-27	Bolt Shoulder
20	532 15 97-70	Baffle Vortex 42
21	873 68 05-00	Nut Crownlock 5/16-18 unc
23	532 17 75-63	Bracket Deflector Mower 42"
24	532 10 53-04	Cap Sleeve 80 x 112 Blk Mower
25	532 12 37-13	Spring Torsion Deflector 2 52
26	532 11 04-52	Nut Push Phos & Oil
27	532 17 18-59	Shield Deflector Mower 42" Blk
28	819 11 10-16	Washer 11/32 x 5/8 x 16 Ga.
29	532 13 14-91	Rod Hinge 42" 6 75 Wlg
30	532 17 39-84	Screw Thd Rolling Washer Head
31	532 18 76-90	Washer Spacer
32	532 15 35-35	Pulley Mandrel 42"
33	532 17 83-42	Nut 9/16 Toplock Fling Oil Dip
34	872 14 06-14	Bolt Rdhd 3/8-16 unc x 1-3/4
36	532 13 14-94	Pulley Idler Flat 3 060
40	873 90 06-00	Nut 3/8-16 unc

KEY NO.	PART NO.	DESCRIPTION
44	532 14 00-88	Guard Mandrel LH Black
45	532 12 47-88	Spring Retainer 1" Zinc/cad
46	532 13 77-29	Screw Hex Thd Cut 1/4-20 x 5/8 T
48	532 13 39-44	Washer Hardened Smaller
52	532 13 98-88	Bolt Shoulder 5/16-18 unc Blkz
53	532 18 49-07	Arm Asm Pad Brake
54	532 17 85-15	Washer Hardened
55	532 15 50-46	Arm Idler 42"mower LT/YT
56	532 16 57-23	Spacer Retainer Mower
59	532 14 10-43	Guard TUV Idler
67	532 10 69-32	Knob Rd 3/8-16 Plstc Thds Blk
68	532 18 02-15	V-Belt Mower 42"
142	532 16 58-90	Arm Spring Brake Mower
143	532 15 71-09	Bracket Arm Idler 42"
144	532 15 86-34	Keeper Belt 42" Clutch Idler
145	532 16 58-88	Pulley Idler Flat
146	532 17 19-77	Bolt Carriage Idler
147	532 17 97-48	Spring Extension
148	532 16 90-22	Spring Return Idler
149	532 16 58-98	Retainer Spring Yellow
150	819 09 12-10	Washer 9/32 x 3/4 x 10 Ga.
152	532 18 15-55	Clutch Cable 42"
158	817 72 04-08	Screw Hex Thd Cut 1/4-20 x 1/2
159	872 11 06-12	Bolt Carr. Sh 3/8-16 x 1-1/2 Gr. 5
184	819 13 14-10	Washer 13/32 x 7/8 x 10 Ga.
185	532 18 82-34	Head asm. Cable Clutch
--	532 13 07-94	Mandrel Asm Service (Includes Housing, Shaft and Shaft Hardware Only-Pulley Not Included)
--	532 18 19-25	Replacement Mower, Complete

NOTE: All component dimensions given in U.S. inches
1 inch = 25.4 mm

REPAIR PARTS

TRACTOR - MODEL NO. WZ125107B, PRODUCT NO. 964 77 35-02

MOWER LIFT

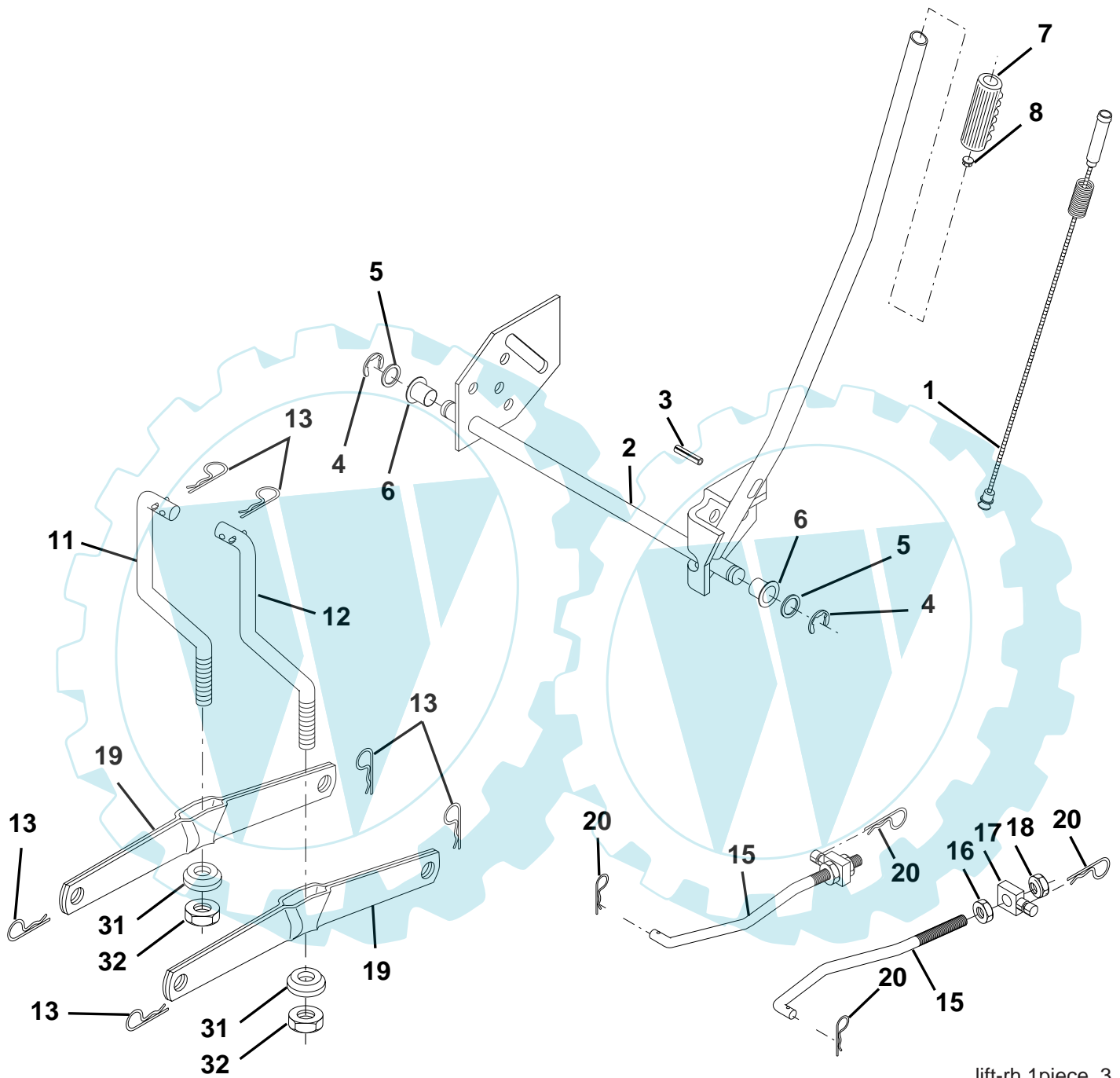

lift-rh.1piece_3

REPAIR PARTS

TRACTOR - MODEL NO. WZ125107B, PRODUCT NO. 964 77 35-02
MOWER LIFT

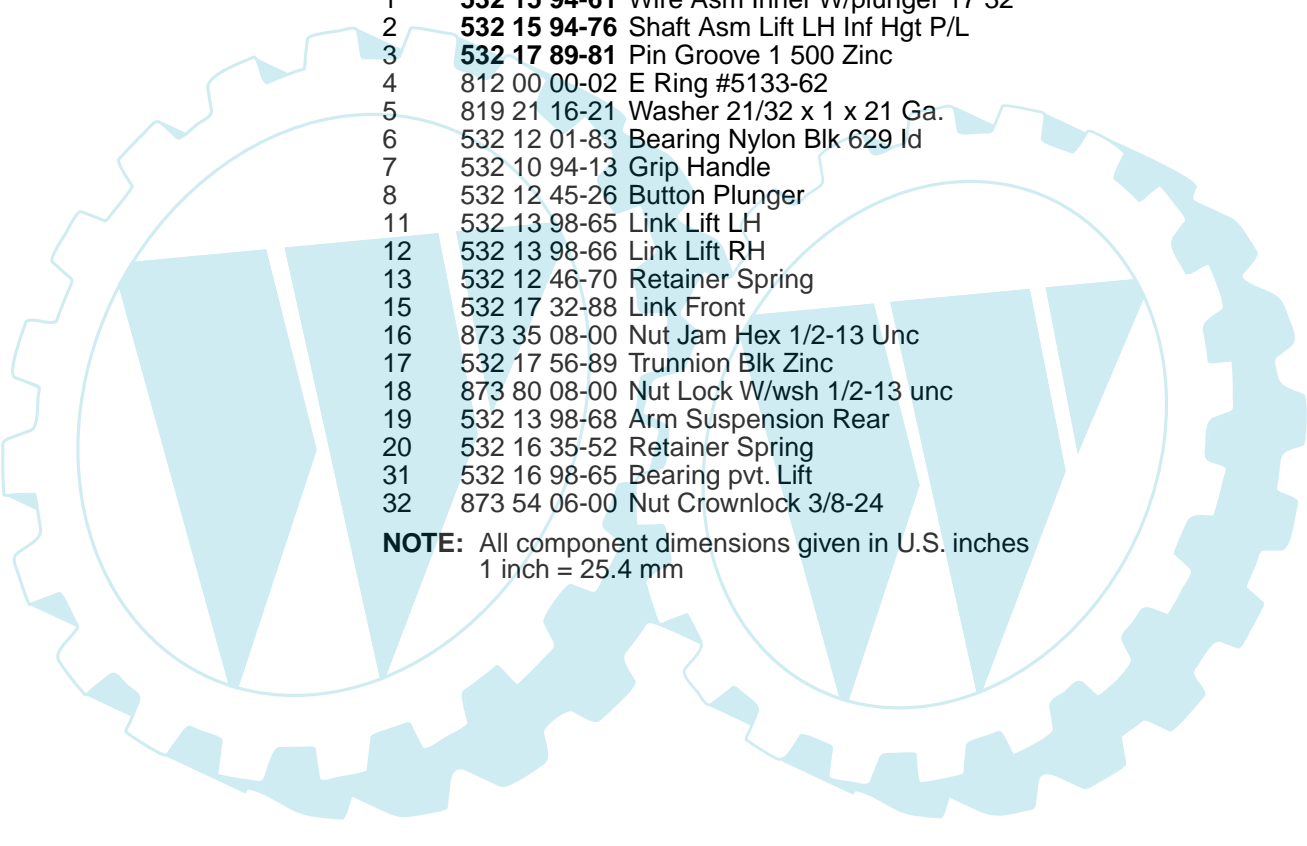

KEY NO.	PART NO.	DESCRIPTION
1	532 15 94-61	Wire Asm Inner W/plunger 17 32
2	532 15 94-76	Shaft Asm Lift LH Inf Hgt P/L
3	532 17 89-81	Pin Groove 1 500 Zinc
4	812 00 00-02	E Ring #5133-62
5	819 21 16-21	Washer 21/32 x 1 x 21 Ga.
6	532 12 01-83	Bearing Nylon Blk 629 Id
7	532 10 94-13	Grip Handle
8	532 12 45-26	Button Plunger
11	532 13 98-65	Link Lift LH
12	532 13 98-66	Link Lift RH
13	532 12 46-70	Retainer Spring
15	532 17 32-88	Link Front
16	873 35 08-00	Nut Jam Hex 1/2-13 Unc
17	532 17 56-89	Trunnion Blk Zinc
18	873 80 08-00	Nut Lock W/wsh 1/2-13 unc
19	532 13 98-68	Arm Suspension Rear
20	532 16 35-52	Retainer Spring
31	532 16 98-65	Bearing pvt. Lift
32	873 54 06-00	Nut Crownlock 3/8-24

NOTE: All component dimensions given in U.S. inches
1 inch = 25.4 mm

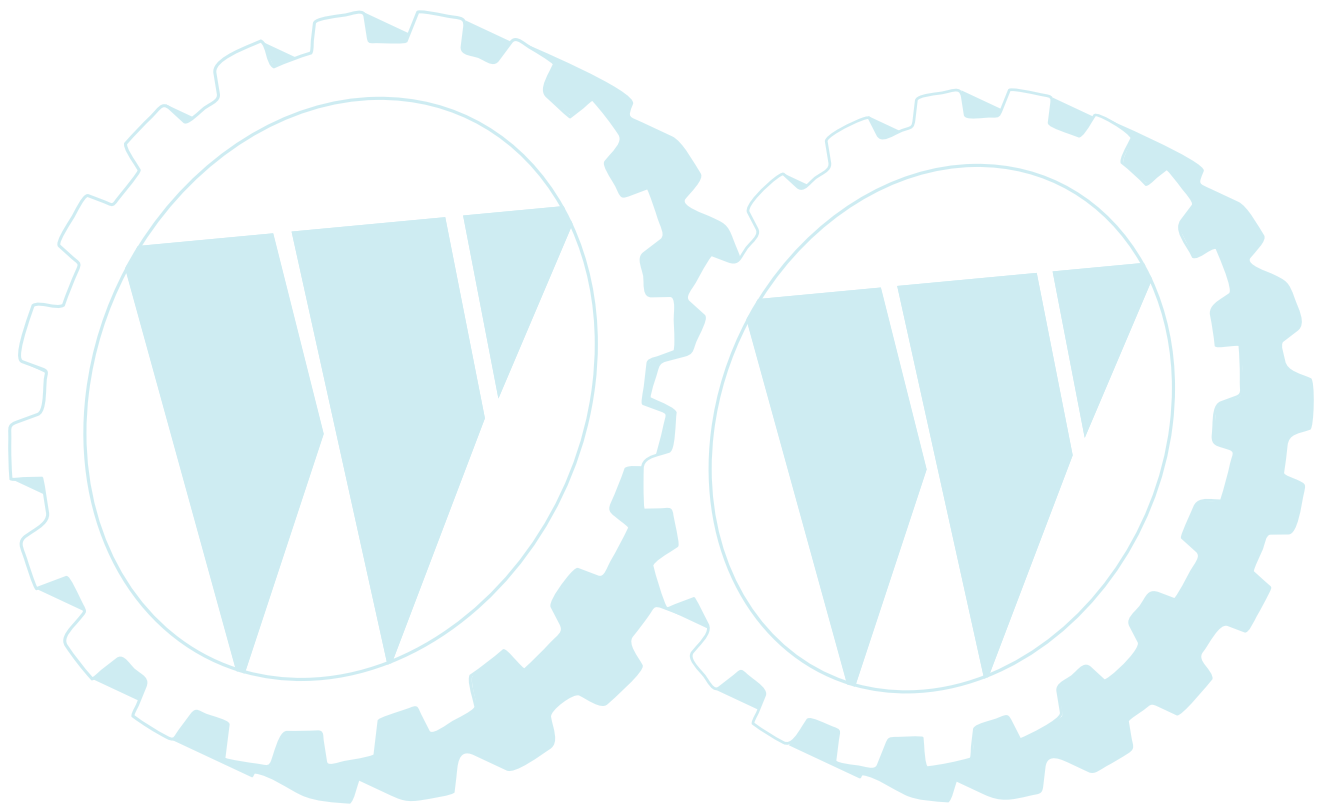

WIZARD

Ihr Ersatzteilspezialist im Internet